

Hiab XS 435 K

Capacity 280,200 ft-lbs



Product brochure



Speedy deliveries 92' up from ground level



Hiab XS 435 K Capacity 280,200 ft-lbs

High performance with little effort

The Hiab 435 K is designed to suit building site needs and it is perfect for drywall deliveries. The crane features a double telescoping inner boom and four telescoping outer boom extensions providing a vertical reach of 92' from ground level. Stabilizers, 23 ft wide, come as standard with an extra set of rear stabilizers for added stability. The Hiab 435 K features Hiab's HiPro control system with remote control CombiDrive² and Valve 91 – which together with a boom system designed for fast load-cycles provide both efficiency and precision. Delivering to rooftops, through windows or onto balconies becomes a smooth operation requiring little effort.

Protection for second boom cylinder rod

The second boom cylinder sits inside the inner boom with a protection for the rod, This provides maximum protection from elements during transport as well as from the metal hooks used on the load's tie-down straps.

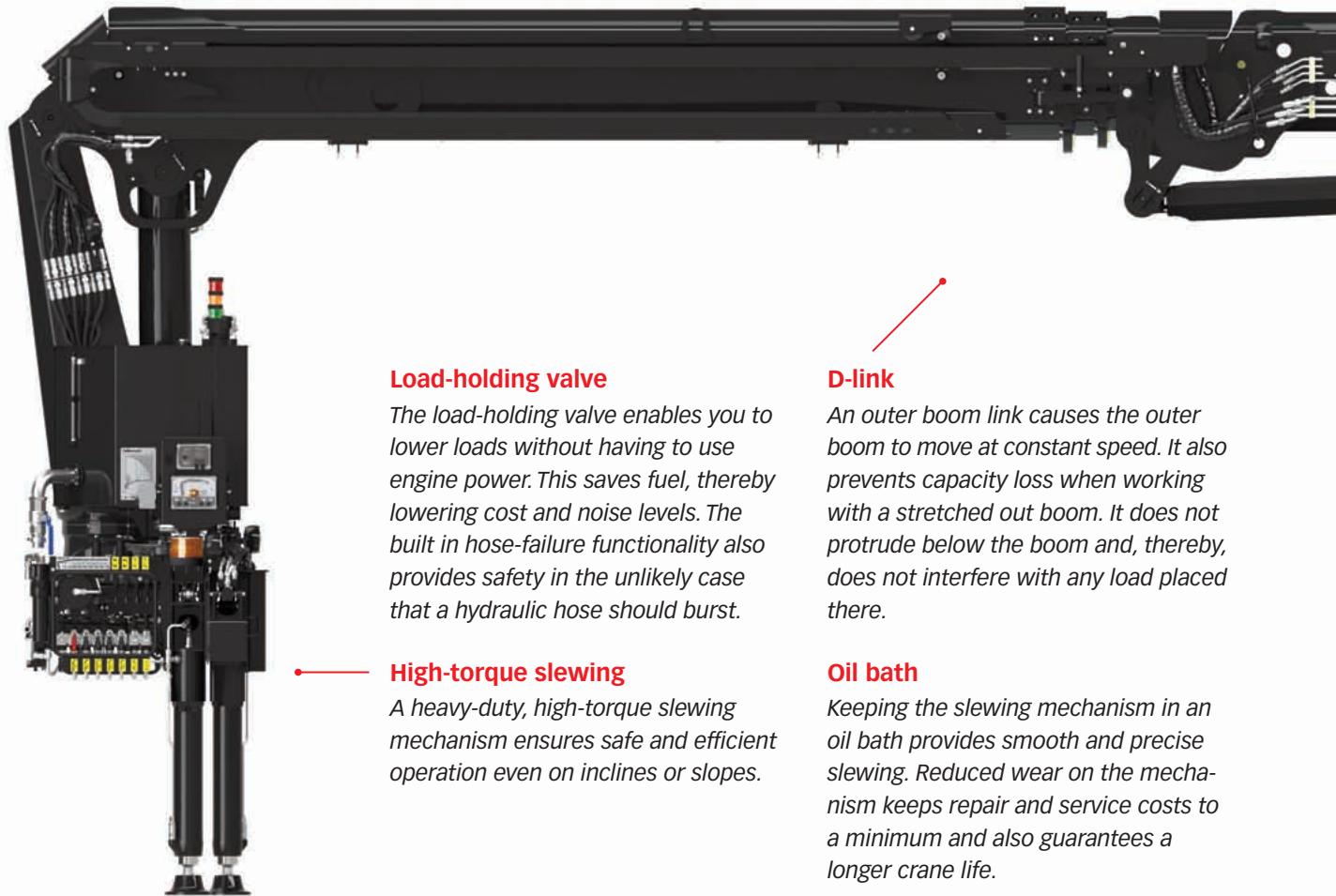

Load-holding valve

The load-holding valve enables you to lower loads without having to use engine power. This saves fuel, thereby lowering cost and noise levels. The built in hose-failure functionality also provides safety in the unlikely case that a hydraulic hose should burst.

High-torque slewing

A heavy-duty, high-torque slewing mechanism ensures safe and efficient operation even on inclines or slopes.

D-link

An outer boom link causes the outer boom to move at constant speed. It also prevents capacity loss when working with a stretched out boom. It does not protrude below the boom and, thereby, does not interfere with any load placed there.

Oil bath

Keeping the slewing mechanism in an oil bath provides smooth and precise slewing. Reduced wear on the mechanism keeps repair and service costs to a minimum and also guarantees a longer crane life.

Internally mounted extension cylinders

Having extensions internally mounted, so called telescopic, keeps them well protected from being struck by loads or other types of damage.



Side supports for stability

Side supports fitted on each boom extension stabilize the boom laterally and minimize the play. This increases precision and is especially beneficial on boom systems with long outreach.



Standard drywall pallet fork

The pallet fork provides maximum efficiency when handling palletized goods and stacked drywall. A counterbalance valve prevents self-acting unfolding.



JIC couplings

JIC couplings are standard on most Hiab cranes. They ensure easy and secure coupling, but are still very simple to disconnect for service.



Hexagonal boom profile

The hexagonal profile ensures the boom is always in perfect balance, thanks to its shape and large support surface. The profile also minimizes boom deflection, which reduces maintenance costs and increases efficiency.



Protected hose tracks

All hose tracks are robust and well protected to prevent damage, i.e. from excessive road vibration in transport and tie down straps.



HiPro control system

HiPro is simply the most advanced control system on the truck-crane market today, delivering unrivalled speed, precision and safety. This is achieved by combining the CombiDrive² remote control, SPACE 5000 intelligence and Valve 91. Capacity is increased significantly by Automatic Speed Control (ASC). Pump Flow Distribution (PFD) maximizes productivity by ensuring super-smooth operation at all times.

Valve 91

The Hiab Valve 91 represents the pinnacle of hydraulic valve technology. It is load-sensing and pressure-compensated which improves both speed and precision. It features a long range of top class abilities, among one is that the same control lever movement always produces the same crane response, whether you are using one or more functions, with light or heavy load. The Hiab Valve 91 also allows for Pump Flow Distribution (PFD) which keeps the crane operating independently of the available oil flow. This keeps the lifting and other crane functions running simultaneously at the same relative speed. The Hiab Valve 91 gives your crane the ability to be controlled with fingertip precision regardless of how far out the crane tip is, invaluable in confined spaces.

CombiDrive²

With the Hiab CombiDrive² you can benefit from information, precision, feel and function – to a higher degree than with anything else on the market. Three active displays give access to vital information from your crane. A live symbol indication function ensures that the correct lever symbol is shown at all times – no matter what function is currently running on each lever. The lever response is outstanding, enabling load handling with finger-tip feel and precision.

The weight of the CombiDrive² is approximately 2.3 kg.



Valve 91

The Hiab Valve 91 represents the pinnacle of valve technology, handling very large oil throughputs. It is a closed-centre, pressure-compensated, load-sensing control valve, providing the operator with finger-tip feel when handling the crane.



CombiDrive² remote control

With the Hiab CombiDrive² you can position yourself at the best possible location when operating the crane. It features 24 proportional and 12 on/off functions for controlling the crane, optional equipment and accessories, all with the same precision.

Double telescoping inner boom

The crane has a sturdy, double telescoping inner boom and four telescoping outer boom extensions which give the crane its awesome reach.









Front runners in boom design

A Hiab crane is built to withstand extreme loading under all kinds of circumstances, in all field conditions. Keeping the boom reliable, tough and sturdy under extreme loading has made Hiab a world leader in crane boom engineering. Taking a closer look at the crane, one can point out a number of features that our customers benefit from.

Attention to details built-in

The built-in features of Hiab 435 K have been given the center of attention. Vital parts, such as load holding valves and second boom cylinder, are well protected to reduce maintenance costs. Also, all the hose tracks are robust and well protected to prevent damage from excessive road vibration in transport and contact with tree branches, tie down straps and the like.

Less diesel and wear, higher speed when needed.

The Hiab 435 K comes fitted with variable pump as standard. A variable pump provides the crane exactly with the oil flow needed, meaning that the amount of oil pumped around in the system is reduced. Pumping less oil naturally requires less diesel – consequently both carbon dioxide emission and fuel cost are lowered. Another effect of pumping less oil is that less energy is converted to heat. This reduces wear and in most cases also the need for an oil cooler. On average, a Hiab drywall crane with its hydraulic system and variable pump, will consume 325 gallons less diesel fuel per year compared to other models using fixed displacement pumps. You save money and our environment is spared 7,200 lbs of carbon dioxide.



Productivity at its best

Design innovation – driven by you

Hiab is part of Cargotec, renowned throughout the world for innovation and engineering excellence. The quality and reliability of our cranes are without equal in the truck loader market. But there is another crucial factor in our global success. We have a philosophy of listening, and responding, to the needs of those who matter most – the people who own and operate our cranes. The design and development of every crane we manufacture are customer-driven. This will become really clear when using your Hiab loader crane.



Atlas Polar
IT'S ALL ABOUT QUALITY™

Atlas Polar Company Ltd.
60 Northline Road
Toronto, ON M4B 3E5
Canada
1-888-799-4422
info@atlaspolars.com
www.atlaspolars.com