

# Hiab XS 088 CLX

## Capacity 59,300 ft-lbs



# Hiab XS 088 CLX Basic data

| Technical data                                      | B-1 CLX        | B-2 CLX        | B-3 CLX         | E-4 CLX        | E-5 CLX         |
|---|----------------|----------------|-----------------|----------------|-----------------|
| Max. lifting capacity (ft-lbs)                      | 59,330         | 56,440         | 54,990          | 52,820         | 51,370          |
| Outreach - hydraulic extensions                     | 18' 8"         | 25' 3"         | 31' 10"         | 38' 1"         | 44' 11"         |
| Outreach - manual extensions                        | 30' 2"         | 37' 1"         | 37' 1"          | 44' 11"        | -               |
| Outreach / Lifting capacity, standard (ft / lbs)    | 5'11" / 9,590  | 5'11" / 9,260  | 5'11" / 9,040   | 8' 6" / 6,220  | 8' 10" / 5,820  |
|   | 7' 10" / 7,500 | 9' 2" / 6,220  | 10' 2" / 5,470  | 13' 9" / 3,790 | 14' 1" / 3,530  |
|   | 12' 6" / 4,720 | 12' 6" / 4,450 | 12' 10" / 4,100 | 19' 0" / 2,560 | 19' 4" / 2,380  |
|   | 17' 9" / 3,350 | 17' 9" / 3,090 | 18' 1" / 2,780  | 25' 3" / 1,810 | 25' 7" / 1,630  |
|   | -              | 23' 7" / 2,290 | 23' 11" / 2,030 | 31' 6" / 1,410 | 31' 10" / 1,230 |
|   | -              | -              | 30' 2" / 1,590  | 38' 1" / 1,150 | 38' 5" / 970    |
|   | -              | -              | -               | -              | 44' 11" / 820   |
| Slewing angle                                       | 400 - 406°     | 400 - 406°     | 400 - 406°      | 406°           | 406°            |
| Height in folded position                           | 79"            | 79"            | 79"             | 79"            | 79"             |
| Width in folded position                            | 83"            | 86"            | 88"             | 91"            | 94"             |
| Installation space needed                           | 27"            | 27"            | 30"             | 28"            | 31"             |
| Weight - "standard" crane without stabilizers (lbs) | 2,140          | 2,380          | 2,580           | 2,780          | 2,950           |
| Weight - stabilizer equipment (lbs)                 | 310 - 630      | 310 - 630      | 310 - 630       | 310 - 630      | 310 - 630       |

## Hiab XS 088 E-5 CLX

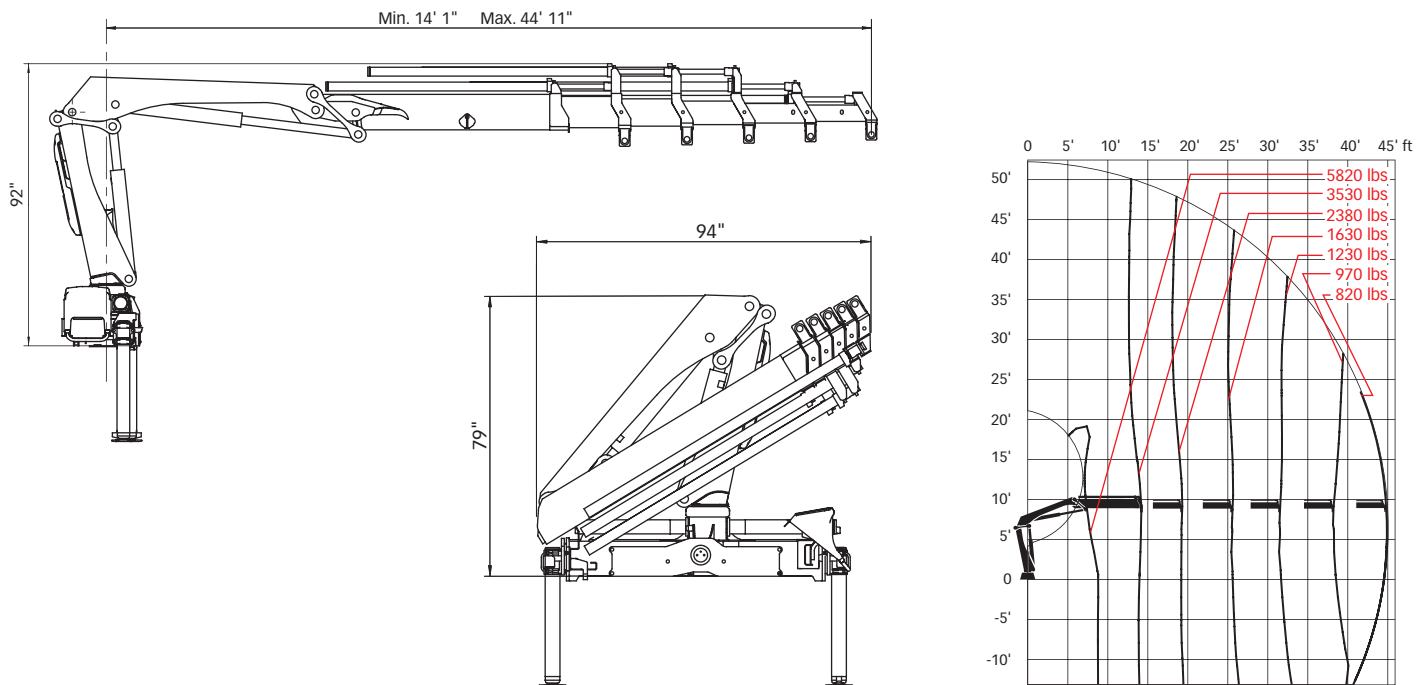

**Disclaimer.** Hiab cranes have been built to meet the highest standards of safety and service life and have been thoroughly tested. Strength calculations for this model have been carried out in accordance with EN13001 in fatigue class S2. Cargotec's certified Quality Assurance System complies with ISO 9001. Some of the items in our literature may be extra equipment. Certain applications may require an official permit. We reserve the right to change technical specifications without prior notice. Hiab cranes produced for EU-countries are CE-marked and comply with the European Standard EN 12999.

**Cargotec** improves the efficiency of cargo flows by offering solutions for the loading and unloading of goods on land and at sea – wherever cargo is on the move. Cargotec's main daughter brands for cargo handling Hiab, Kalmar and MacGregor are global market leaders in their fields. [www.cargotec.com](http://www.cargotec.com)