

Hiab XS 088

Range 6-9 tm



Product brochure



E-link

An inner boom link makes it possible to lift a heavier load close to the column, and the outer boom link helps in lifting to higher positions such as scaffolding. The outer boom link does not protrude below the boom and thereby does not interfere with any load placed under the boom.

Column close to centreline

On Hiab cranes with a rack-and-pinion slewing housing the centre of gravity is as close to the centreline as possible. This means that the same outreach is offered on both sides of the truck.

Load-holding valve

The load-holding valve is a combined hose-failure and load-holding valve which is mounted on the cylinder.

The complete solution

The Hiab XS 088 exceeds your expectations

Hiab has consistently led the way forward with innovative truck crane design achieving unrivalled levels of crane performance. The Hiab XS 088 is an extraordinary crane in the 8 tonne-metre class where meticulous attention to detail has resulted in a crane package that not only meets your needs, but exceeds all your expectations in terms of performance, reliability and low cost of ownership. The crane can be delivered with the CL, Duo or HiDuo control system.

HiDuo control system

The HiDuo control system is based upon the renowned Hiab Valve 80. HiDuo comes with the SPACE 4000 intelligence system which intelligently monitors and controls the electronic functions of your crane. These functions are focused on assisting the operator in two aspects, safety and productivity. The HiDuo control system support remote controlling with the XSDrive remote control.

SPACE 4000 intelligence system

The SPACE 4000 system intelligently monitors and controls the electronic functions of your crane. These functions are focused on assisting the operator in two aspects, safety and productivity. Safety is managed by an Over Load Protection (OLP) function and productivity is increased by the Automatic Duty Control (ADC) and the Hiab unique Automatic Speed Control (ASC) functions. Further more, the system handles functions primarily used by service personnel such as fault code indication and load cycle data. The SPACE 4000 is a part of the HiDuo control system.

Versatility to meet your demands

An optional second boom link makes the second boom move at a constant speed, resulting in smoother and more precise performance. The second boom link can also be complemented by a first boom link giving extraordinary lifting capacity in high boom positions. You can also order the crane with a short outer boom. This increases lifting height when for example loading a second-layer pallet close to the column.



Hexagonal boom profile

The hexagonal profile ensures the boom is always in perfect balance, thanks to its shape and large support surface. The profile also minimizes boom deflection, which reduces maintenance costs and increases efficiency.

Large slide pads

Large slide pads reduce friction and wear keeping, maintenance costs low. Also the Hiab boom system needs no greasing, and thus it is kept cleaner than those of our competitors'.

Attachable tools

A wide range of attachable tools are available for your Hiab crane. These make sure you can carry out a lot of different tasks.



XSDrive

The Hiab XSDrive has been ergonomically developed to relieve you of stress and strain in hands, arms and back. The load indicators provide information for quick and correct actions while work is on-going. There are also a number of accessories that can be added in order to find the ideal control solution for you.



Valve 80

The Hiab Valve 80 is a top-of-the-line open-centre valve based on well-proven technique which gives superb reliability. The valve handles large oil flows and provides great precision and ease of operation.

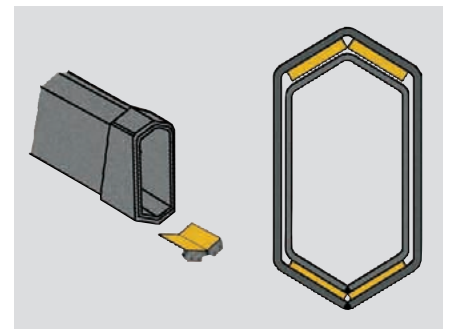

Large slide pads

The hexagonal profile enables the use of larger slide pads. This makes the extensions move more smoothly and reduces mechanical wear on the boom.



Atlas Polar
IT'S ALL ABOUT QUALITY™

Atlas Polar Company Ltd.
60 Northline Road
Toronto, ON M4B 3E5
Canada
1-888-799-4422
info@atlaspolar.com
www.atlaspolar.com