

Hiab XS 077

Range 6-8 tm



Product brochure



Column close to centreline

On Hiab cranes with a rack-and-pinion slewing housing the centre of gravity is as close to the centreline as possible. This means that the same outreach is offered on both sides of the truck.

Load-holding valve

The load-holding valve is a combined hose-failure and load-holding valve which is mounted on the cylinder.

State of the art versatility

The Hiab XS 077 is performance at its best

The flexibility of the XS manufacturing technique, gives you the Hiab XS 077, offering the complete crane solution. For versatile, efficient and reliable performance, no other crane in the 7 tonne-metre class comes close. Hiab gives you more functionality, higher standards of safety and greater productivity than ever before. The crane can be delivered with the CL, Duo or HiDuo control system.

Duo control system

The Duo crane gives you all the benefits of the CL model, plus an extra boost of capacity. This is because the control system features a function called Automatic Duty Control (ADC), which senses the job being done. A Duo crane is equal in weight to the corresponding CL model, offering you an improved weight-capacity ratio.

SPACE 3000 intelligence system

The SPACE 3000 is the basic electronic system for intelligently monitoring and controlling the electronic functions. These functions are focused on assisting the operator in two aspects, safety and productivity.

Safety is managed by an Over Load Protection (OLP) function and productivity is increased by the Automatic Duty Control (ADC) function.

Further more, the system handles functions primarily used by service personnel such as fault-code indication and load-cycle data. Equipped with these functions the SPACE 3000 is a part of the Duo control system.

Mechanics for improved efficiency

The crane has an optional E-link solution which gives excellent lifting capabilities when working with a fully stretched boom system, useful when scaffolding. You can also order the crane with an optional short second boom. This S-boom system increases lifting height close to the column, proving very useful when for example loading a second-layer pallet close to the column.

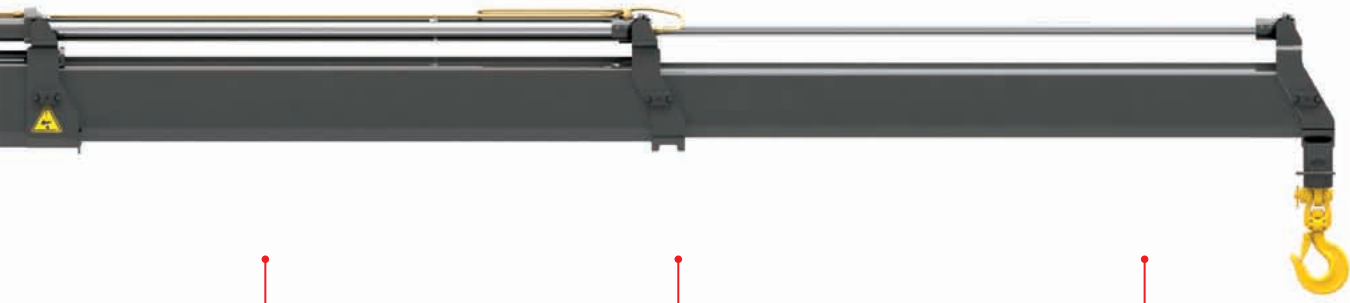

Hexagonal boom profile

The hexagonal profile ensures the boom is always in perfect balance, thanks to its shape and large support surface. The profile also minimizes boom deflection, which reduces maintenance costs and increases efficiency.

Large slide pads

The hexagonal profile enables the use of larger slide pads. This makes the extensions move more smoothly and reduces mechanical wear on the boom.

Attachable tools

A wide range of attachable tools are available for your Hiab crane. These make sure you can carry out a lot of different tasks.



Side controls

The levers are positioned at the crane base. Cross-controls give the same sequence of levers on both sides. As an option the levers can be positioned at a control platform or high seat.



Valve 80

The Hiab Valve 80 is a top-of-the-line open-centre valve based on well-proven technique which gives superb reliability. The valve handles large oil flows and provides great precision and ease of operation.

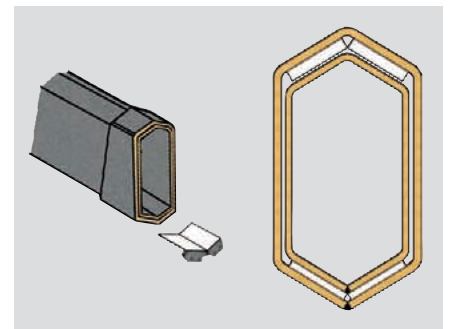

Hexagonal boom profile

The hexagonal profile used on Hiab booms is a ground-breaking design introduced by Hiab many years ago. It is now standard throughout the market for loader cranes. Even the smallest Hiab crane benefits from this design.



Atlas Polar
IT'S ALL ABOUT QUALITY™

Atlas Polar Company Ltd.
60 Northline Road
Toronto, ON M4B 3E5
Canada
1-888-799-4422
info@atlaspolar.com
www.atlaspolar.com