



# Hiab XS 055 CLX Capacity 36,200 ft-lbs



Product brochure



#### **Column close to centerline**

On Hiab cranes with a rack-and-pinion slewing housing, the center of gravity is as close to the centerline as possible. This means that the same outreach is offered on both sides of the truck.

---

#### **Load-holding valve**

The load-holding valve is a combined hose-failure and load-holding valve, which is mounted on the cylinder.

## For all-around performance

### **The Hiab XS 055 CLX is a giant in disguise**

The Hiab XS 055 CLX combines all the features and benefits you look for in a knuckle boom crane, and a lot more. When you want compatibility with your fleet of medium size trucks, the Hiab XS 055 CLX delivers just that. Despite being such a compact crane, it delivers all-around performance that will definitely exceed your expectations for lifting capacity.

### **Designed for the tough jobs, every day**

Hiab designs cranes for rough and tough operation, and this crane is no exception. The crane is designed to be on the job, day in and day out, where it belongs; however, unscheduled servicing is necessary from time to time. In order to keep servicing time as short as possible, we have fitted the crane with JIC couplings and easily replaceable large slide pads. Before you know it, the crane is back at the jobsite, doing what it does best: creating solutions and versatility for your business.

### **CLX control system**

The CLX control system gives you an excellent and versatile crane, providing all the functionality you need to perform a wide range of general cargo handling tasks. CLX cranes are controlled manually via side controls. Optional solutions, such as a control platform, are also available. The CLX crane's hydraulic system features load holding valves with an integrated hose failure function, as well as port relief valves to prevent overloading the crane. The main control valve is the Hiab Valve 80, which enables the crane to perform more than one crane function at a time, smoothly and efficiently.



### Hexagonal boom profile

The hexagonal profile ensures that the boom is always held in perfect balance, thanks to its shape and large support surface. The profile also minimizes boom deflection, which reduces maintenance costs and increases efficiency.

### Large slide pads

The hexagonal profile enables the use of larger slide pads. This makes the extensions move more smoothly and reduces mechanical wear on the boom.

### Attachable tools

A wide range of attachable tools are available for your Hiab crane. These enable you to carry out many different tasks.



### Side controls

The levers are positioned at the crane base. Cross-controls give the same sequence of levers on both sides. As an option, the levers can be positioned at a control platform.



### Valve 80

The Hiab Valve 80 is a top-of-the-line open-center valve, based on a well-proven technique which gives superb reliability. The valve handles large oil flows and provides great precision and ease of operation.

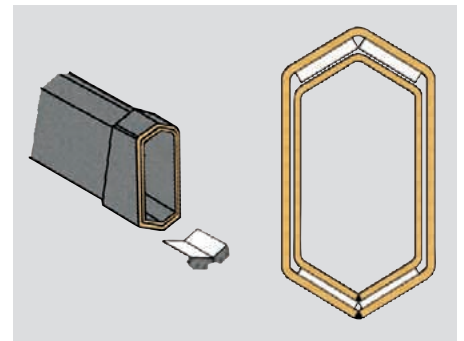

### Hexagonal boom profile

The hexagonal profile used on Hiab booms is a ground-breaking design introduced by Hiab many years ago. It is now standard throughout the market for loader cranes. Even the smallest Hiab crane takes advantage of this design.



**Atlas Polar**  
IT'S ALL ABOUT QUALITY™

Atlas Polar Company Ltd.  
60 Northline Road  
Toronto, ON M4B 3E5  
Canada  
**1-888-799-4422**  
[info@atlaspolars.com](mailto:info@atlaspolars.com)  
[www.atlaspolars.com](http://www.atlaspolars.com)