



# HIAB 033 T



# HIAB 033 T – it makes light work of heavy-duty loading tasks

One of Hiab's most popular truck loader ranges has just got bigger and better with the introduction of the new HIAB 033 T.

This new addition to Hiab's highly successful T series has been developed for installation on utility trucks used for moderately heavy loading operations. Available with 2 or 3 hydraulic extensions, the 033 T has a lifting capacity of almost 2.5 tonnes at close range and an outreach of up to 6 metres, making it ideal for handling e.g. heavy gardening equipment, medium size machines or building material.

As with all its sister cranes throughout the T series, the 033 T features Hiab's renowned and well proven hexagonal boom geometry, self-locking worm gear slew drive and built-in BOSS safety system. It also features the robust

design, reliability and neat compact dimensions which characterise every crane that carries the Hiab name.

The HIAB 033 T is designed to bring you a rapid return on your investment. Driven through the truck's power take off (PTO), the 033 T can run continually without compromising performance, thereby maximising productivity. For less demanding and less frequent periods of operation, the crane can be powered by a separate power pack. High efficiency is combined with the reduced operating costs that result from a design focus on low maintenance and long, trouble-free service life.

For a more powerful solution to your truck loader needs, the HIAB 033 T has got what it takes – and more besides.

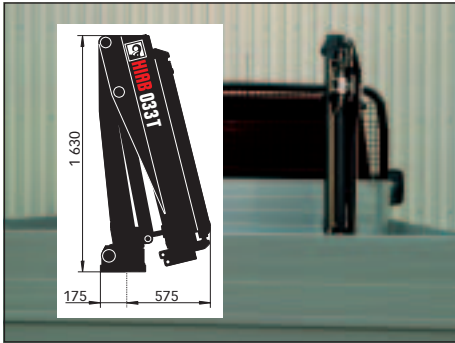

The HIAB 033 T requires the minimum of platform space, and it is so low that it goes in under most pick-up-truck covers.



The control valve and BOSS® safety and control system (on CE-marked cranes) are placed in a protective box.

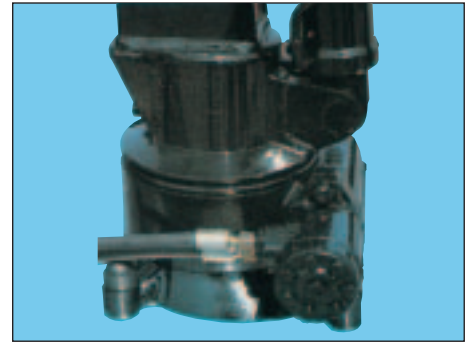

Slewing housing of cast steel with an encased worm gear prevents water and dirt from entering.

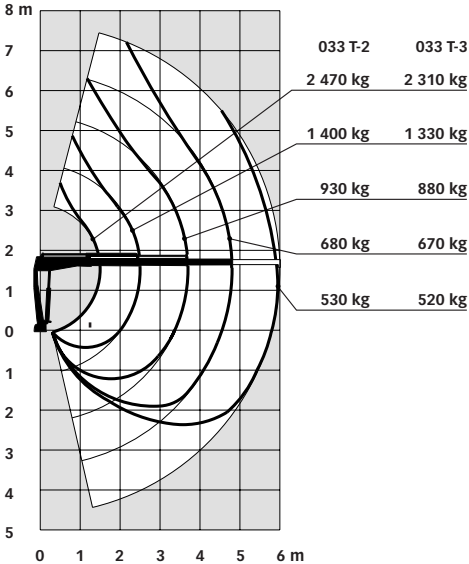

## Technical data

Capacity class	
Outreach, hydraulic	
Lifting height above base with manual extension(s)	
Outreach/lifting capacity	
	with manual extension(s)
Slewing angle	
Weight in standard version	
Manual support leg, short/long	
Hydraulic support leg, short/long	

## HIAB 033 T-2

32.8 kNm (3.3 tm)
3.6 m
5.2 m
7.5 m
1.4 m/ 2 470 kg
2.4 m/ 1 400 kg
3.6 m/ 930 kg
4.8 m/ 680 kg
6.0 m/ 530 kg
295 kg
12/15 kg
15/20 kg

## HIAB 033 T-3

31.7 kNm (3.2 tm)
4.8 m
6.3 m
7.5 m
1.5 m/ 2 310 kg
2.5 m/ 1 330 kg
3.7 m/ 880 kg
4.8 m/ 670 kg
6.0 m/ 520 kg
335 kg
12/15 kg
15/20 kg

The HIAB 033 T has been built to meet the highest standards of safety and service life and have been thoroughly tested. Strength calculations have been carried out in accordance with the German DIN norm 15018, crane group B 2. Hiab's CE-marked cranes comply with the EU's Machinery Directive. Hiab's certified Quality Assurance System complies with the ISO 9001.

NOTE. Some of the items we describe in our literature may be extra equipment. Certain applications may require an official permit. We reserve the right to change technical specifications without prior notice.

For complete technical data, consult our folder "HIAB 033 T – Technical Data".

For more information about the HIAB 033 T, or any other Hiab crane, please contact your local Hiab distributor.



The World's No.1 Selling Articulated Crane  
HIAB is a Partek Cargotec Company