

Multilift

Introducing
the New
XR7

XR



Xtra Capacity
Xtra Versatility

The All New Multilift XR 7
Loads 8 Tons with Standard
Multilift Containers



Multilift XR7



XR7N

(Handles same containers as HL4 and HL5)
16,000 lb. Capacity
11 – 14 ft. containers
50 degree dump angle

XR7L

(Handles same containers as HL4 and HL5)
16,000 lb. Capacity
12 – 15 ft. containers
50 degree dump angle

XR7XL (Extra Long)

15,500 lb. Capacity
14 – 17 ft. containers
50 degree dump angle

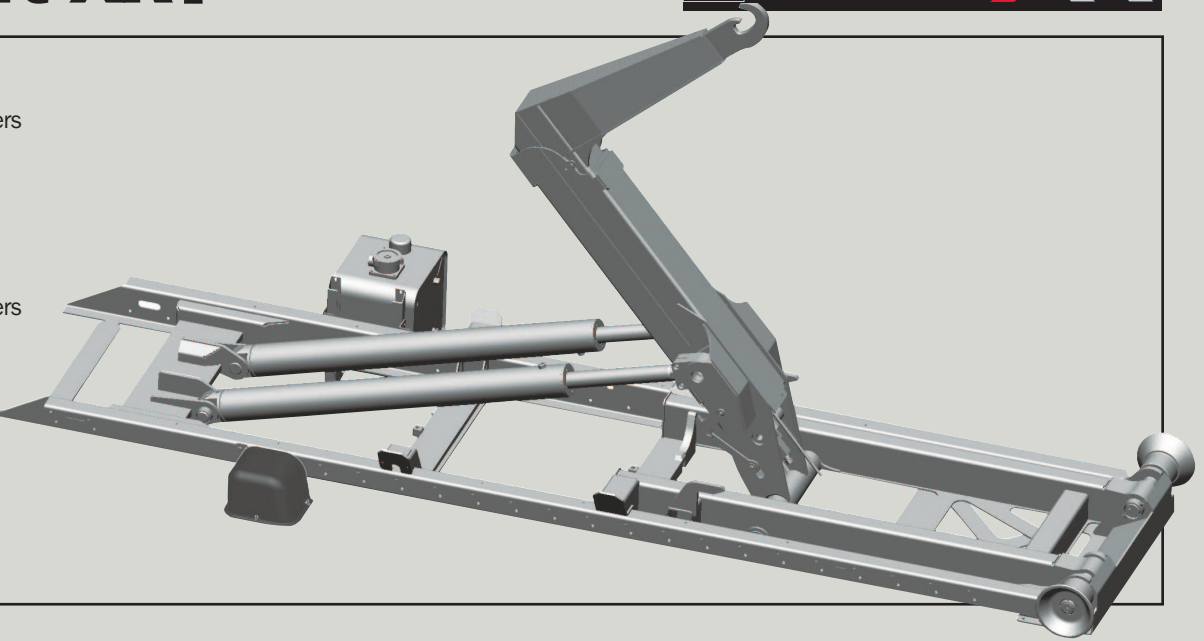

The All New XR 7

The new XR hooklift system is a major breakthrough in Multilift technology. This unique, pioneering concept is based on a sliding hook mechanism and innovative new single-plate subframe.

The result is a product that delivers outstanding performance with fast, easy body mount and demount functions. And that's not all. The XR range also brings you unrivalled levels of reliability and safety plus smooth, efficient, trouble-free operation.

The XR more than pulls its weight

The XR 7 hooklift has a lift capacity of 8 tons, but in terms of productivity it more than pulls its weight. Twin cylinders are located centrally for even distribution of forces.

A lower operating radius during mounting and demounting makes the XR system ideal for use on low-height applications.

The XR 7 Xtra Reliable

The exceptional low weight, high strength ratio gives greater payloads, increasing the versatility of the vehicle and maximizing its lift capacity even on higher truck frames. The XR 7 is fully compatible with the smaller Multilift containers. Well-proven components and easy-to-use hydraulic systems and controls assure outstanding reliability. Maintenance and repairs are reduced to an absolute minimum. In short, the XR offers a rapid return on your investment, low cost of ownership throughout its extended working life and high resale values.

Advanced safety features for total peace of mind

Multilift never compromises on safety and the XR sets a new benchmark of excellence in this vital area. The well-proven Multilift construction incorporates a mechanically operated tipping lock and mechanical container locking. All hydraulic cylinders are fitted with load holding valves and a pilot-operated double check valve to support the load even if a hose should burst.

Advanced safety functions make it almost impossible for the operator to make a wrong move. Interlocks guarantee safe hydraulics operation. The direct electrical controls are simple to use, fast and accurate.

A commitment to quality

Multilift is totally committed to maintaining standards of quality that provide a benchmark of excellence for the industry. Our XR Hooklift systems are built to meet or exceed demanding European standards and fulfil EU machine directives.

Call 1 888 799 4422 and book a demonstration now.



1-888-799-4422

info@atlaspolar.com

www.atlaspolar.com