

HIAB XS 033 Range 2.8-3.3 tm

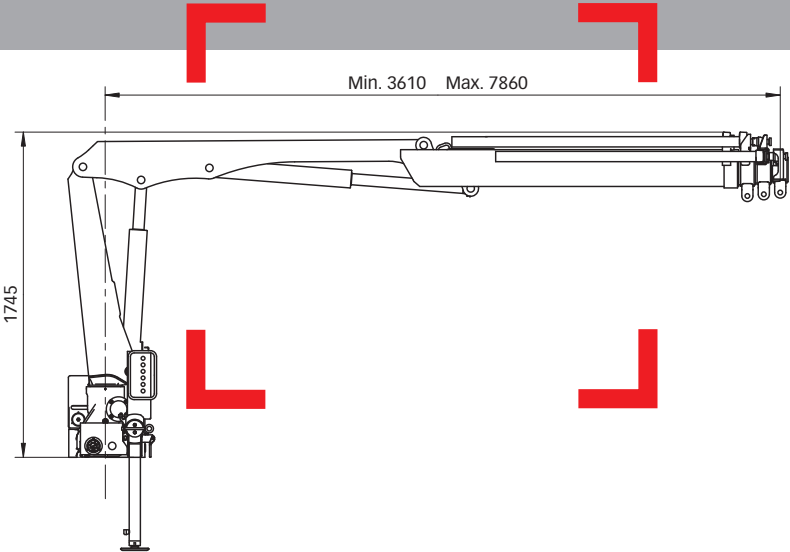

Basic data

HIAB XS 033 Basic data

Technical data

	B-1 CLX	D-4 CLX	B-1 Duo	D-4 Duo	B-1 HiDuo	D-3 HiDuo
Max. lifting capacity (kNm)	29	29	29	29	29	30
Outreach - hydraulic extensions (m)	4.9	9.4	4.9	9.4	4.9	9.4
Outreach - manual extensions (m)	8.0	-	8.0	-	8.0	-
Outreach / lifting capacity, standard (m / kg)	3.4 / 840	3.6 / 780	3.4 / 840	3.6 / 780	3.4 / 840	3.6 / 820
	4.7 / 600	4.8 / 560	4.7 / 600	4.8 / 560	4.7 / 600	4.8 / 600
	-	6.3 / 400	-	6.3 / 400	-	6.3 / 440
	-	7.7 / 310	-	7.7 / 310	-	7.7 / 350
	-	9.2 / 260	-	9.2 / 260	-	-
Slewing angle	380°	380°	380°	380°	380°	380°
Height in folded position (mm)	1610	1610	1610	1610	1610	1610
Width in folded position (mm)	1890	1890	1890	1890	1890	1890
Installation space needed (mm)	535	600	535	600	535	580
Weight - "standard" crane without stabilizers (kg)	445	570	445	570	445	535
Weight - stabilizer equipment (kg)	56	56	56	56	56	56

HIAB XS 033 D-3 HiDuo

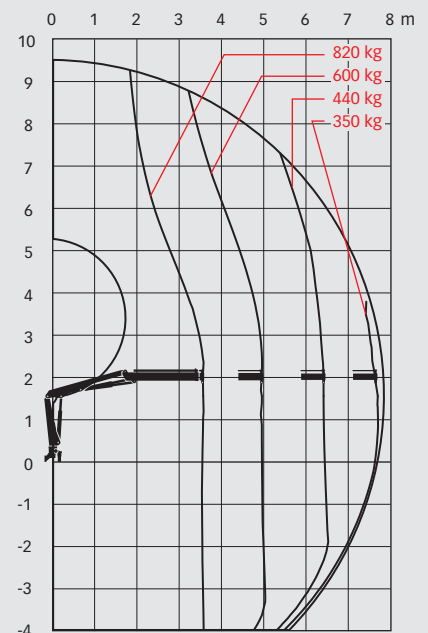
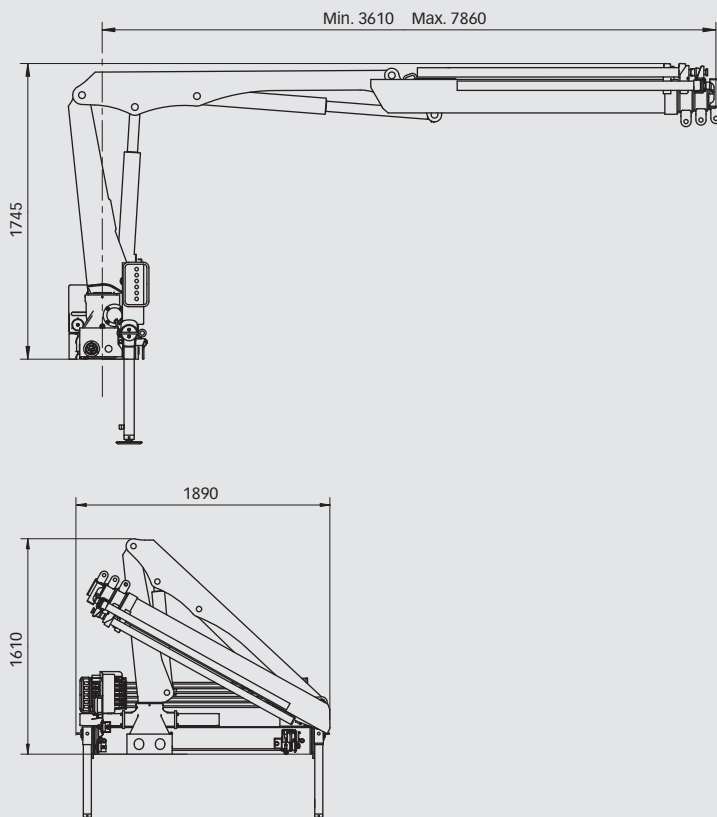

Disclaimer

Hiab cranes have been built to meet the highest standards of safety and service life and have been thoroughly tested. Strength calculations for this model have been carried out in accordance with EN13001. Hiab's certified Quality Assurance System complies with the ISO 9001. Some of the items in our literature may be extra equipment. Certain applications may require an official permit. We reserve the right to change technical specifications without prior notice. Hiab cranes produced for EU-countries are CE-marked and comply with the European Standard EN 12999.