

Lumber



Block



Shingles



Extend the Possibilities with Same-Side Unloading



Completely unload your truck or trailer from one side with Moffett Mounty Pantograph and Lift Assist®.

- Save time on the job site
- Speed up deliveries
- Improve operator safety

The **Pantograph** hydraulically extends fully across the truck or trailer bed so the forks engage in the load. The **Lift Assist**® arms hydraulically fold up and rest against the truck or trailer bed providing the additional capacity to lift the load from the other side. The **Lift Assist**® arms maintain gentle contact with the truck or trailer bed while permitting free movement for mast side shift and tilt.



Moffett Mounity

Truck mounted forklifts



Moffett Mounity

M8 55.3PL

Moffett Mounity Model	M8 55.3PL (10 ft mast)	M8 55.3PL (12ft mast)
TYPE	PANTOGRAPH AND LIFT ASSIST®	PANTOGRAPH AND LIFT ASSIST®
1 CAPACITY @ 24" LOAD CENTER	5500 lbs (EX 5500 lbs)	5500 lbs (EX 5500 lbs)
2 KUBOTA DIESEL ENGINE (4 CYLINDER)	50 hp	50 hp
3 HYDROSTATIE DRIVE WHEELS	3	3
4 TIRE TYPE	31X15.5-15 8 PLY	31X15.5-15 8 PLY
5 MAXIMUM SPEED	7 mph	7 mph
6 MAXIMUM GRADABILITY	30%	30%
7 UNLADEN WEIGHT (INCL. MAST & FORKS)	7084 lbs	7230 lbs
8 TILT OF MAST (FORWARD/BACK)	10°/8°	10°/8°
9 SIDESHIFT	5"	5"
10 FORK SECTION	48"x 4"x 2"	48"x 4"x 2"
11 MAST CARRIAGE TRAVEL (PANTOGRAPH REACH)	37" (48")	37" (48")
A HEIGHT TO TOP OF OVERHEAD GUARD	100 1/4"	100 1/4"
B OVERALL WIDTH	101"	101"
C OVERHANG	68"	68"
D LIFT HEIGHT	120"	144"
E GROUND CLEARANCE	12 1/2"	12 1/2"
F ANSI STANDARD	B56.6	B56.6

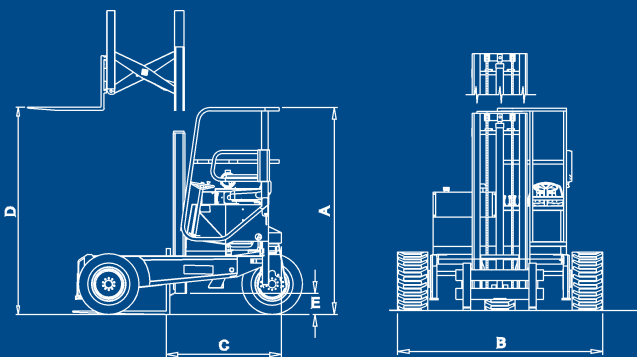

The above specifications are not binding upon the manufacturer and may be changed without prior notice. Weights may vary depending on tire and/or fork option.

Designed and Manufactured by:
Moffett Engineering Limited,
Ardee Road, Dundalk,
Co Louth, Ireland



Nylon wear pads on the Lift Assist Arms maximize the contact area and minimize contact pressure on the bed rails providing optimum lift assistance.

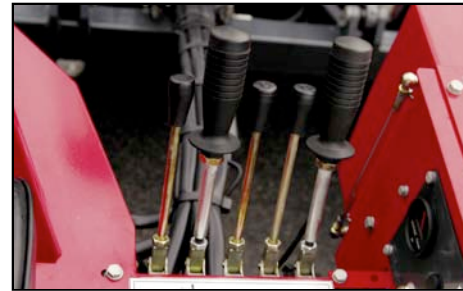

The Carriage Travel/Pantograph functions and the Stabilizer/Lift Assist functions are electro-hydraulically sequenced to ensure safe and precise load handling.



Long Drop Class III Forks ensure optimal strength and visibility.



The Central Pivot Shafts in the Pantograph have thrust pads that are fully adjustable with grease zerks to provide wear resistance, ensure smooth operation, and long life.



The Delivery Challenge:

To unload a truck or trailer on narrow streets and restricted job sites with limited turn around space and tight delivery schedules.

The Delivery Solution:

The Moffett Mounity with long reach Pantograph and new Lift Assist® arms for same-side unloading.