

# Hiab XS 166

## Range 13-17 tm



Product brochure



Delivering great functionality



# Hiab XS 166 Range 13–17 tm

## The Hiab XS 166 provides excellence

Innovative world leading engineering has resulted in a first class crane in the 13–17 tonne metre range. Behind the sleek, low headroom boom profile of the Hiab XS 166 lies a crane with total flexibility and productivity. The slewing mechanism runs in an oilbath for reduced friction and noise. Throughout the crane JIC couplings are fitted for easy maintenance. Everything is focused on giving you the ideal crane and a quick return on your initial investment. The crane can be delivered with the CL, Duo, HiDuo, Pro or HiPro control system.

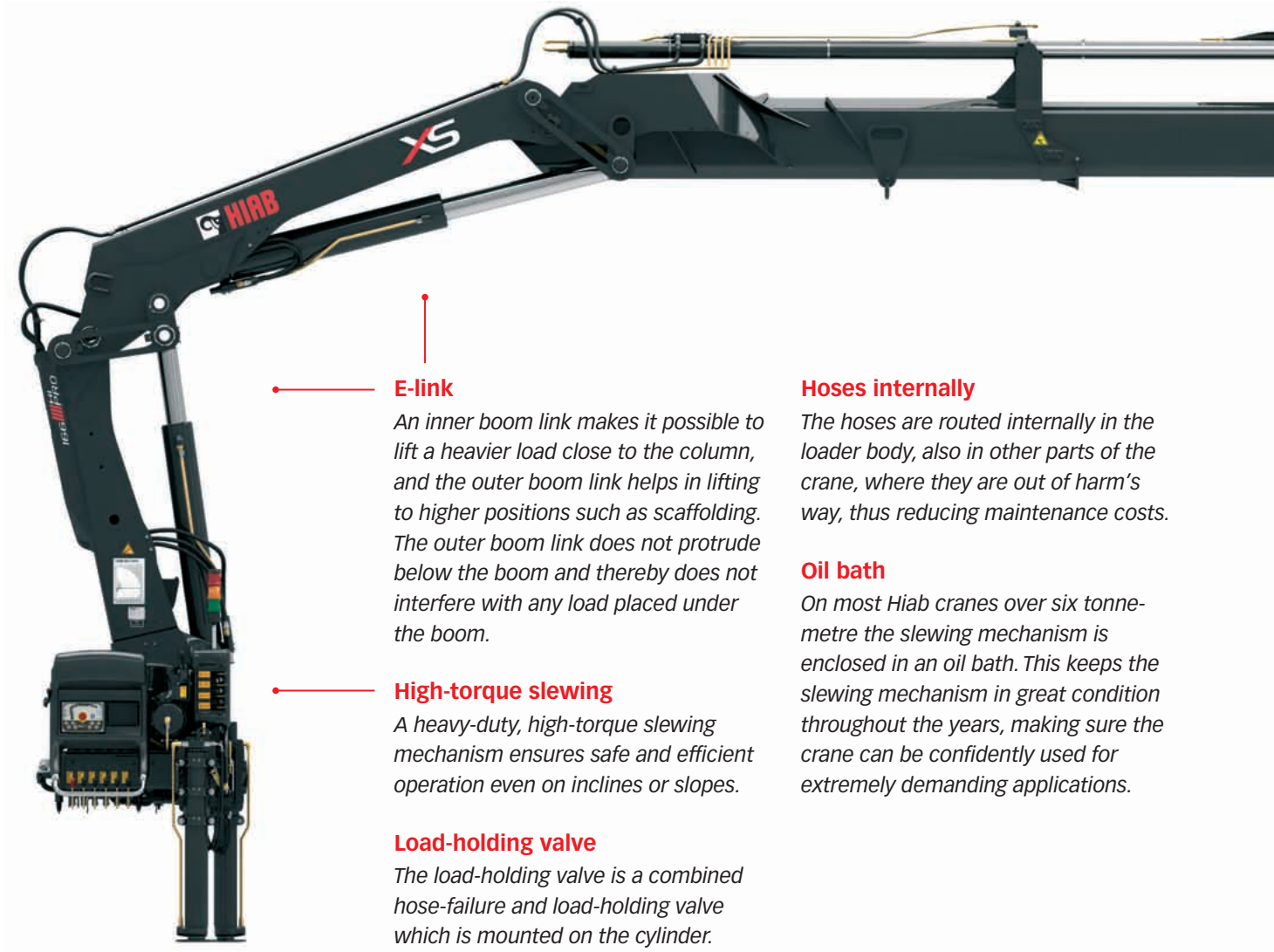

### E-link

An inner boom link makes it possible to lift a heavier load close to the column, and the outer boom link helps in lifting to higher positions such as scaffolding. The outer boom link does not protrude below the boom and thereby does not interfere with any load placed under the boom.

### High-torque slewing

A heavy-duty, high-torque slewing mechanism ensures safe and efficient operation even on inclines or slopes.

### Load-holding valve

The load-holding valve is a combined hose-failure and load-holding valve which is mounted on the cylinder.

### Hoses internally

The hoses are routed internally in the loader body, also in other parts of the crane, where they are out of harm's way, thus reducing maintenance costs.

### Oil bath

On most Hiab cranes over six tonne-metre the slewing mechanism is enclosed in an oil bath. This keeps the slewing mechanism in great condition throughout the years, making sure the crane can be confidently used for extremely demanding applications.

### **Flexible cylinder positioning**

*Some extension cylinders can be positioned on top of the boom, or side-mounted. This influences the crane's dimensions and enables easier access to confined spaces.*



### **Hexagonal boom profile**

*The hexagonal profile ensures the boom is always in perfect balance, thanks to its shape and large support surface. The profile also minimizes boom deflection, which reduces maintenance costs and increases efficiency.*



### **Side supports for stability**

*The side supports greatly improve the performance when for example excavating or performing other high-stress tasks.*



### **JIC couplings**

*JIC couplings are standard on most Hiab cranes. They ensure easy and secure coupling, but are still very simple to disconnect for service.*



### **Large slide pads**

*The hexagonal profile enables the use of larger slide pads. This makes the extensions move more smoothly and reduces mechanical wear on the boom.*



### **Attachable tools**

*A wide range of attachable tools are available for your Hiab crane. These make sure you can carry out a lot of different tasks.*



### HiDuo control system

The HiDuo control system is based upon the renowned Hiab Valve 80. HiDuo comes with the SPACE 4000 intelligence system which intelligently monitors and controls the electronic functions of your crane. These functions are focused on assisting the operator in two aspects, safety and productivity. The HiDuo control system support remote controlling with the XSDrive remote control.

### HiPro control system

HiPro is simply the most advanced control system on the truck-crane market today, delivering unrivalled speed, precision and safety. This is achieved by combining the CombiDrive<sup>2</sup> remote control, SPACE 5000 intelligence and Valve 91. Capacity is increased significantly by Automatic Speed Control (ASC). Pump Flow Distribution (PFD) maximizes productivity by ensuring super-smooth operation at all times.

### Pump Flow Distribution (PFD)

Hiab cranes can handle the highest oil throughput in the market. But skilled operators, able to operate several functions at the same time, want even more from their crane. And Hiab delivers, with PFD. In situations where the operator is working at the limits and using multiple functions simultaneously, even the largest pump may not be able to supply enough oil. This can result in the crane acting unpredictably, but not if your crane is equipped with PFD. This innovative system distributes the available oil in proportion to the operator's lever movements. All functions will continue to work just as expected with no disturbances or surprises, although you require more oil flow than available. Once full oil flow is restored, it is full speed ahead once again. PFD has proven extremely useful in practice. Even at an oil flow of 100 l/min, the system activates three times per load cycle during normal use. If you demand maximum convenience and productivity from your crane, you should not settle for less than a crane equipped with PFD.



### Valve 80

*The Hiab Valve 80 is a top-of-the-line open-centre valve based on well-proven technique which gives superb reliability. The valve handles large oil flows and provides great precision and ease of operation.*



### XSDrive

*The Hiab XSDrive has been ergonomically developed to relieve you of stress and strain in hands, arms and back. The load indicators provide information for quick and correct actions while work is on-going. There are also a number of accessories that can be added in order to find the ideal control solution for you.*



### Valve 91

*The Hiab Valve 91 represents the pinnacle of valve technology, handling very large oil throughputs. It is a closed-centre, pressure-compensated, load-sensing control valve, providing the operator with finger-tip feel when handling the crane.*



### CombiDrive<sup>2</sup>

*With the Hiab CombiDrive<sup>2</sup> you can position yourself at the best possible location when operating the crane. It features 24 proportional and 12 on/off functions for controlling the crane, optional equipment and accessories, all with the same precision.*



## Intelligence systems

All electronic functions are managed by a SPACE system, which is a computer devised to intelligently assist you in operating your crane. The SPACE electronics are housed in a 100% weather-proof casing and is extremely reliable and easy to use. On the front of the casing a number of indicators clearly show vital information to the operator. As an example, the pressure in the cylinders is displayed continuously. Observing these indicators proves very useful when positioning the booms for lifting loads at maximum capacity.

The SPACE intelligence system is available in different packages, each one with an increasing number of advanced and productive functions.

All SPACE-packages benefit from the highly advanced Over Load Protection (OLP) system. Productivity functions in the system are Automatic Duty Control (ADC), Automatic Speed Control (ASC) and Pump Flow Distribution (PFD). These functions can be used separately or in combination. A valuable feature for service personnel is that fault code indication and load cycle data is also stored in the system. This can be used for analysis and feedback to the customer as to how he or she uses the crane.

### SPACE 4000 intelligence system

The SPACE 4000 system features Automatic Duty Control (ADC) and the Automatic Speed Control (ASC) function. The ASC function boosts capacity in a smooth, stepless motion and thus gives an edge in load handling and capacity that proves very valuable.

The SPACE 4000 is a part of the HiDuo control system.

### SPACE 5000 intelligence system

The SPACE 5000 system features Automatic Duty Control (ADC) and the Automatic Speed Control (ASC) function. The later function boosts capacity in a smooth, stepless motion and in addition to this Pump Flow Distribution (PFD) ensures super-smooth operation at all times.

The SPACE 5000 is a part of the HiPro control system.







### Versatility to meet your demands

In accordance with requirements, your crane can be delivered with an outer boom link (D-link), giving constant outer boom speed. This provides you with smoother and more precise load handling. Ordering a crane with both an inner and outer boom link, equips you with an E-link system, delivering extra capacity when handling loads close to the column, as well as when lifting to high positions. Furthermore, by ordering a short outer boom (S-boom) when customizing your crane, you gain even higher load capacity close to the column and, without detaching the bucket, can park it even on a short tipper body.

### E-link

*An E-link system is a kind of lever connection between the column and the inner boom, as well as the inner and the outer boom. This is beneficial when lifting heavy loads straight up to high positions, such as on scaffolding.*

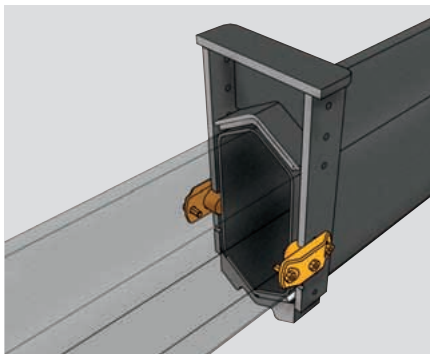

### Side supports for stability

*Side supports fitted on each boom extension stabilize the boom laterally and minimize the play. Most Hiab crane models can be delivered with extension side supports.*



### High boom warning

*When the pressure is on and you need to get to the next job fast, mistakes can happen. For example, if a driver forgets to park the crane, the consequences could be serious. In these situations, you'll appreciate a safety function like high boom warning. The SPACE system continuously monitors the boom position. If the crane is left in its upright position, an indicator lamp in the cabin will alert the driver before driving away.*



# Power and intelligence

## **Operating your crane by remote control**

One of the benefits of Hiab's remote control units is that the crane operator can be positioned at the best possible location when operating the crane. This leads to more efficient, comfortable work and also increases safety. A further spin-off effect is that you can be your own loading assistant positioning yourself next to the load, or wherever the loading assistant should be standing. Tasks will be completed faster and at lower cost.

## **Design innovation – driven by you**

Hiab is part of Cargotec, renowned throughout the world for innovation and engineering excellence. The quality and reliability of our cranes are without equal in the truck loader market. But there is another crucial factor in our global success. We have a philosophy of listening, and responding, to the needs of those who matter most – the people who own and operate our cranes. The design and development of every crane we manufacture are customer-driven. This will become really clear when using your Hiab loader crane.



**Atlas Polar**  
IT'S ALL ABOUT QUALITY™

Atlas Polar Company Ltd.  
60 Northline Road  
Toronto, ON M4B 3E5  
Canada  
**1-888-799-4422**  
info@atlaspolar.com  
www.atlaspolar.com