

HIAB XS 066 Range 5-7 tm

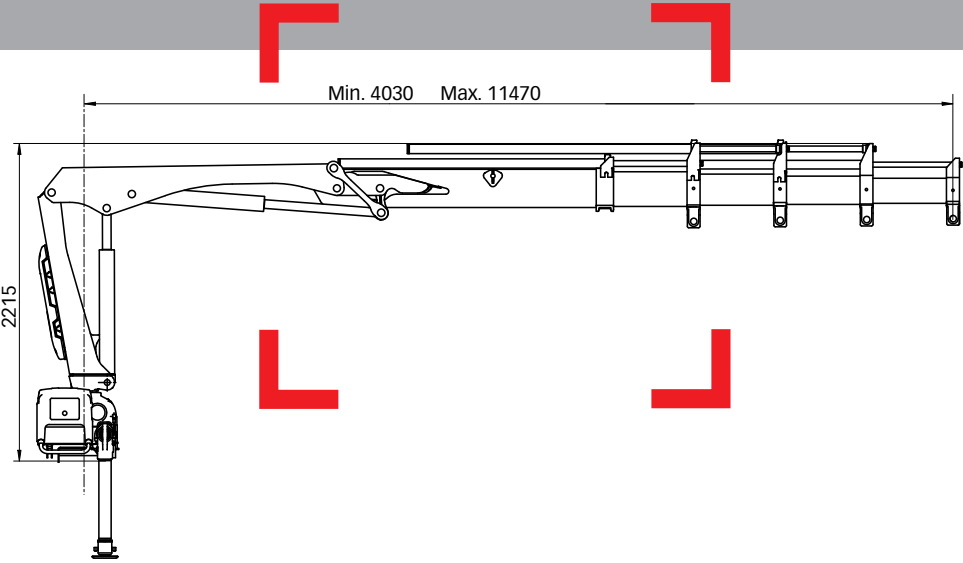

Basic data

HIAB XS 066 Basic data

Technical data

	B-2 CL	D-2 Duo	D-3 HiDuo	D-4 HiDuo
Max. lifting capacity (kNm)	52	57	60	57
Outreach - hydraulic extensions (m)	7.4	7.3	9.3	11.4
Outreach - manual extensions (m)	9.3	11.3	11.3	-
Outreach / Lifting capacity, standard (m / kg)	2.7 / 2000	2.6 / 2250	2.8 / 2200	2.9 / 2000
	3.8 / 1400	3.8 / 1540	3.9 / 1560	4.0 / 1460
	5.3 / 980	5.4 / 1060	5.5 / 1060	5.6 / 980
	7.1 / 720	7.2 / 780	7.3 / 780	7.4 / 700
	-	-	9.2 / 600	9.3 / 540
	-	-	-	11.3 / 420
Slewing angle	410°	410°	410°	410°
Height in folded position (mm)	1900	1900	1900	1900
Width in folded position (mm)	2170	2150	2150	2170
Installation space needed (mm)	565	565	565	565
Weight - "standard" crane without stabilizers (kg)	820	820	895	955
Weight - stabilizer equipment (kg)	98 - 147	98 - 147	98 - 147	98 - 147

HIAB XS 066 D-4 HiDuo

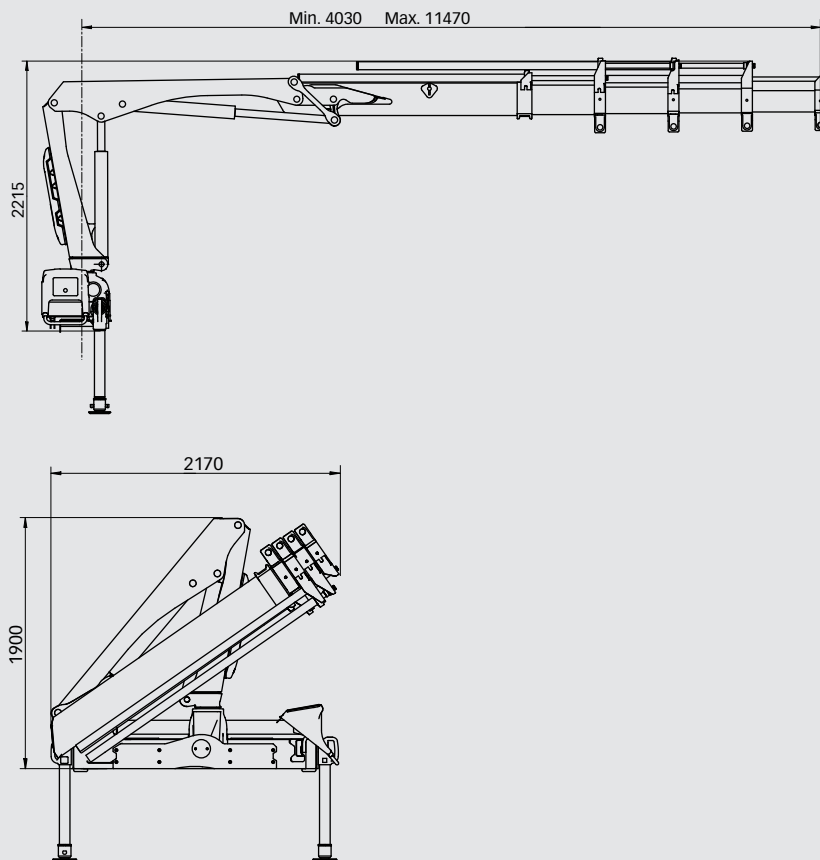

Disclaimer

Hiab cranes have been built to meet the highest standards of safety and service life and have been thoroughly tested. Strength calculations for this model have been carried out in accordance with EN13001. Hiab's certified Quality Assurance System complies with the ISO 9001. Some of the items in our literature may be extra equipment. Certain applications may require an official permit. We reserve the right to change technical specifications without prior notice. Hiab cranes produced for EU-countries are CE-marked and comply with the European Standard EN 12999.