



HIAB X-CLX MID-RANGE CRANES BRIGHTER IN BLACK



ALWAYS THE BRIGHT

When you choose a HIAB mid-range crane, you choose more than good looks. You make a wise choice, because underneath the sleek black finish is a truly versatile workhorse.

Whichever model you select, you do well in selecting a HIAB.

Cranes that stand out

Every one of our HIAB mid-range cranes is built with HIAB quality – and full of smart features that help you do more jobs with less effort. You get a crane to rely on, from the tough-as-nails exterior to the fine response of the hydraulics. Not only will your crane excel in your challenges today, it will stand the test of time to provide a high residual value tomorrow.



CHOICE

Control that lets you shine

Each HIAB mid-range crane is available with a full selection of control systems, which is probably the smartest thing of all. This lets you match your crane to your way of doing things, whether you want a robust solution for basic lifting

and loading or a high-precision solution for the finest remote control.

This brochure focuses on control with the HIAB CLX control system.



BUILT TO PERFORM

HIAB X-CLX mid-range cranes offer strength and durability beyond the norm. The tough crane construction is paired with proven valve technology and the reliable HIAB CLX control system.

More payload and less wear

HIAB X-CLX mid-range cranes are built for strength, using high-tensile steel that combines low weight with the capacity to deliver heavy loads. But they are also built to last, whatever the working conditions. Steel parts are protected by HIAB nDurance, a high-tech finish that defies the elements. And the durable hoses are concealed and routed through the boom structure, thus protecting them from damage.

Control where you need it

Easy steering is a must, which is why HIAB CLX manual control puts the same lever sequence on both sides of the truck. This cross-control, combined with robust and proven valve technology, ensures smooth and intuitive crane operation – which is even better when working from a high seat for an unrestricted view.

All the little extras

Added to this are features that simply make life easier, from effortless tilting of the stabiliser legs to a cylinder layout that offers manoeuvrability in confined spaces. Even maintenance can be kept to a minimum, thanks to smart ideas like slide pads, which need no greasing at all.

Tried and true in every way

Above all, nothing is taken for granted. Each HIAB X-CLX crane is independently tested to certify compliance with European loader crane standards. In fact, European standards are only a beginning. HIAB standards, verified through extensive laboratory testing, go even further to ensure quality, performance and long crane life.



“There’s nothing tougher than my HIAB X-CLX crane. It’s that simple.”

BRIGHTER IN BLACK

HIAB X-CLX mid-range cranes are packed with features that make them the smart choice for lasting versatility – right down to their durable black finish. Light yet heavy-duty, they work swiftly and reliably with HIAB CLX manual control.



Steel with high tensile strength

HIAB CLX gives you robust control

HIAB CLX is a rugged and reliable manual control solution. It has a cross-control setup, which simplifies operation by placing the same lever sequence of both sides of the truck.

HIAB CLX provides rapid response to lever movements, which means jobs can be done quickly – and well. It can be counted on for many years of top-notch operation, even when working in the toughest conditions.



nDurance

HIAB nDurance protects the crane from the elements with the best in surface protection. Technologically advanced and environmentally sound, this high-tech painting system first shields the crane's parts with an ultra-thin nanoceramic layer that prevents corrosion. Afterwards they receive a lacquer polymer e-coating and a durable powder coating, creating stunning good looks that will last the crane's lifetime.

nDurance

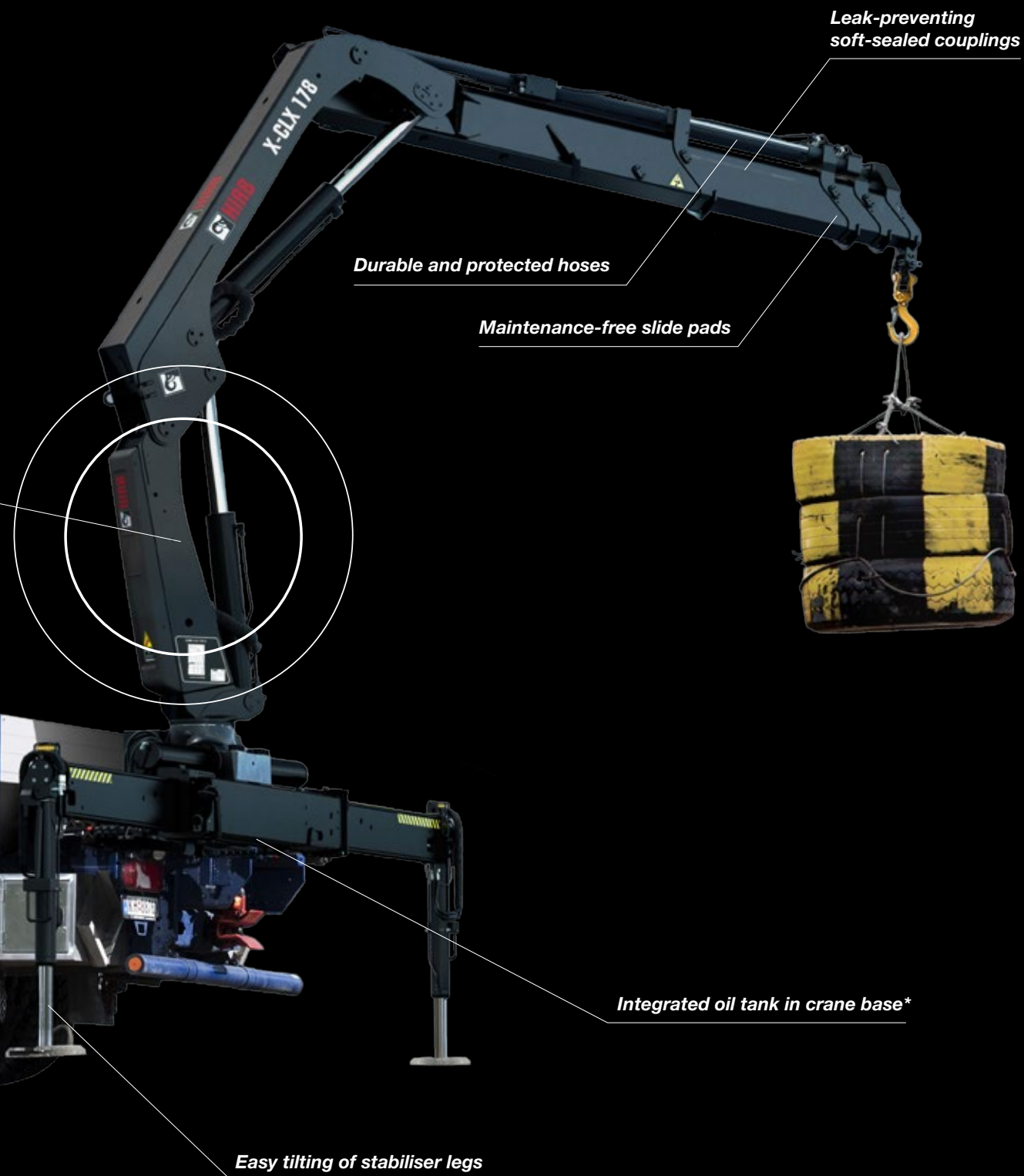

*Leak-preventing
soft-sealed couplings*

Durable and protected hoses

Maintenance-free slide pads

*Integrated oil tank in crane base**

Easy tilting of stabiliser legs

* Standard or optional, depending on crane model

Oil-filled slewing house

The slewing house functions as an oil bath, cooling and reducing friction to increase the life of the slew bushing and rack-and-pinion gearing.

Durable and protected hoses

Tough materials ensure hose integrity and machine performance under the toughest weather conditions. The hoses are concealed and routed through the boom's steel structure to protect against damage.

A MID-RANGE CRANE

No matter what type of loads you move, there is a HIAB X-CLX mid-range crane to match. Our offering covers a full range of loading capacities, and we tailor a solution that meets your requirements in every detail. Your choice of control system is only a start.

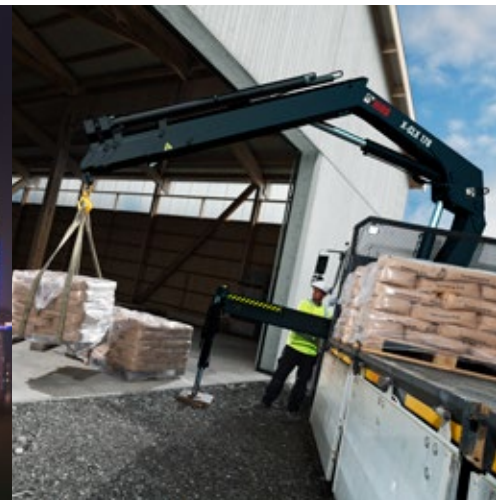

Technical data	HIAB X-CLX 128	HIAB X-CLX 148	HIAB X-CLX 178
Lifting capacity (kNm)	120	139	163
Lifting capacity (tm)	12.2	14.2	16.6
Outreach, hydraulic extensions (m)	6.3-15.1	6.3-15.1	6.5-17.5
Installation space required, rotation area not included (mm)	815-963	815-969	865-985
Height in folded position (mm)	2238-2261	2238-2261	2260-2265
Weight in standard version, without stabilisers (kg)	1290-1920	1380-2090	1610-2450
Weight, stabiliser equipment (kg)	244-385	244-385	271-428
Features			
nDurance	Standard	Standard	Standard
Base mounted oiltank	Option	Option	Option
Cross control	Standard	Standard	Standard
High seat	Option	Option	Option
B-link	Standard	Standard	Standard
E-link	Option	Option	
E-link and X-feature			Option
P-Boom			
Load holding valves	Standard	Standard	Standard

FOR EVERY NEED

The right boom for the right job

With up to four hydraulic extensions, the B-link boom system essentially creates a crane without boom links, which is ideal for lift-and-load applications. If long outreach is more vital, the E-link boom system provides up to six hydraulic extensions, which allows higher positioning and lifts further away from the truck.

Certain HIAB mid-range crane models are also available with an EP boom system, where the E-link construction has been optimised for fewer but longer extensions. This unique construction provides even more power for lifting close to the truck.



HIAB X-CLX 218	HIAB X-CLX 248	HIAB X-CLX 288
192	214	248
19.6	21.8	25.3
6.3-12.6	8.0-15.1	8.0-15.1
846-987	1070-1153	1070-1153
2269-2278	2393	2393
1690-2260	2390-2900	2600-3110
271-428	381-465	381-465
Standard	Standard	Standard
Option		
Standard	Standard	Standard
Option		
Standard		
Option	Standard	Standard
	Standard	Standard
Standard	Standard	Standard

CONTROL FOR EVERY

HIAB mid-range cranes are sold with a full selection of the market's best control systems. More than just manual or remote, the choice depends on how you work and the level of precision you need.

Manual control systems

Reliable and durable, HIAB manual control systems are easy to learn and operate. They give you solid all-round performance for a very reasonable investment.

HIAB CLX*

HIAB CLX is a robust, no-nonsense choice that lets you handle a variety of lifting and loading tasks with ease. Manual cross-control provides the same sequence of levers on both sides of the truck, which lets you operate from either side for the best safety and efficiency.

**Availability dependent on local regulations.*

HIAB Duo

Like HIAB CLX, the HIAB Duo control system has a cross-control setup with the same lever sequence on both sides of the truck. But HIAB Duo takes manual control further. Besides giving you great lifting and loading performance, it incorporates a range of safety features and capacity-enhancing Automatic Duty Control (ADC).



SITUATION

Remote control systems

Remote control lets you work from a safe distance away or right where the action is – always with an unobstructed view. HIAB remote control systems are our most advanced, with a high level of safety and smart functions that give you added capacity when you need it.

HIAB HiDuo

HIAB HiDuo is a choice for high efficiency and value. It ensures great performance and fast load cycles, for example by allowing you to perform several actions simultaneously. The crane responds instantly to your lever movements and provides added stability even during vertical lifts, which means you have full control over the load at all times.

HIAB HiPro

HIAB HiPro is simply the best of the best, offering top versatility and precision for the very highest productivity. Its high flow of oil creates ultra-quick and ultra-smooth response, with support for a large number of simultaneous movements. That brings out the best in both crane and operator, ensuring rapid load cycles, total safety and the lowest lifetime cost.



ACCESSORIES THAT ENH

Extend the versatility of your HIAB mid-range crane by adding one or more tools from the wide range of HIAB accessories. Manufactured to the highest standards, they enhance functionality and performance.



Rotator

A sturdy rotator is an important workhorse, especially when it comes to handling heavy or bulky loads with precision. We offer a wide range of gear-type and vane-type rotators, with shaft or flange attachments for connecting them to other accessories.



Pallet fork

Handling loads with a pallet fork has a number of advantages. Above all a pallet fork is less expensive than the main alternative – a brick grab. Also, since the load is palletised and lifted from underneath, it is possible to lift many different types of loads – including soft and flexible loads as well as solid ones.



Earth drills

Robust earth drills are optimal solutions for fencing, road signs, landscaping, tree planting, well borings, screw piles and sound barrier installations. The drills are available in three motor sizes and with a wide variety of auger dimensions up to 1000 mm. Different tooth types are also available, as well as extensions for drilling holes to a maximum depth of five metres.

When choosing Hiab Selected Accessories, you can be sure to get the most out of your equipment. Hiab Selected Accessories live up to the market-leading Quality and Performance standards set by Hiab.



ANCE YOUR EQUIPMENT



EASY TO MOUNT, EASY TO SERVICE

When you choose a HIAB mid-range crane, you choose a crane that will stay with you over the long haul. Hiab will be with you too, providing world-class service and support. Our commitment to quality and reliability goes beyond the crane itself to include parts, services and preventive maintenance.

Thinking ahead

HIAB mid-range cranes are optimally built for easy mounting on the truck chassis. The whole installation, including any necessary chassis reinforcements, is designed for the lowest possible overall weight.

To make installing your crane simple and quick, we provide complete documentation including technical data, installation instructions and software for calculating axle loading and stability.

Your time is valuable

HIAB mid-range cranes are designed for easier everyday maintenance. Key parts and components that require regular attention are located where you would expect them, and where they are easy to access. A good example is the integrated oil tank in the crane base, which can be installed without rearranging truck components and is quicker and simpler to reach.

When more is required, our fully trained and accredited service personnel know all there is to know about your HIAB crane. Above all, they know the importance of servicing or repairing it as quickly as possible. With the absolute minimum downtime, they get your product back in business and making a profit.

From parts to people

Original spare and wear parts of the highest quality ensure that your HIAB mid-range crane will always be a HIAB product. In other words, they give you the same functionality, performance and safety you have chosen from the start.

With the largest service network in the industry, you are never far away from our skills and expertise. Like our cranes, our people work harder and go further for you.

Hiab ProCare™ for planned performance

In every way, our aim is to keep you moving so you can deliver as promised. With Hiab ProCare™*, we can take on the burden of inspections, planned maintenance, scheduling and more, giving you the best assurance to produce as planned. Simply choose the level of service agreement that makes sense for your business:

Hiab ProCare™ Inspection makes it simpler and easier to comply with inspection regulations for your crane. With the thorough yet efficient scheduled inspections, it is possible to prevent a number of unpleasant surprises and you are back on the road fast.

Hiab ProCare™ Essentials is the best addition to your new crane, including the preventive maintenance programme and scheduled inspections as recommended by Hiab. Put your maintenance planning in our hands and we keep your crane operating with the original high performance to avoid un-necessary cost and downtime.



* Check the availability of service agreements with your local Hiab distributor



Sales and Service network

Hiab's global network offers extensive services that ensure the continuous, reliable and sustainable performance of our equipment. We have the most comprehensive distribution network in the industry, supporting all Hiab's customers – through more than 1500 sales and service outlets. This service network guarantees that we are always close to you, ready to give advice on applications and provide service and spare parts.



Atlas Polar
IT'S ALL ABOUT QUALITY™

Atlas Polar Company Ltd.
60 Northline Road
Toronto, ON M4B 3E5
Canada
1-888-799-4422
info@atlaspolar.com
www.atlaspolar.com