

HIAB 200 C capacity 20 tm



Product brochure



For maximum **all-round** performance



The HIAB 200 C for multiple tasks

Here is a crane with power and high capacity, a real jack-of-all-trades. The HIAB 200 C is ideally suited to work with a whole range of accessories including clamshell buckets, grapples and more. It is designed to give you more all-round benefits. As with every Hiab crane, quality engineering, outstanding performance and advanced safety thinking is at the very heart of the design. The crane has remarkably low weight which makes it ideal for installation at the rear of the truck, and that's not all. The 200 C requires very little mounting space, which gives you more room for your payload.

Flexibility and great reach

Equipped with up to five hydraulic extensions the HIAB 200 C reaches over 14 metres. The long reach is achieved while still keeping the boom system low in weight, this is due to the use of extra-high-tensile steel. The crane is delivered with manual control levers. As an option your crane can be delivered with a remote control. A crane with a remote control provides even more flexibility, efficiency and profit to your business.

Front runners in boom design

A Hiab crane is built to withstand extreme loading under all kinds of circumstances, in all field conditions. Keeping the boom reliable, tough and sturdy under extreme loading has made Hiab a world leader in crane boom engineering. Taking a closer look at the crane, one can point out a number of features that our customers benefit from.

Hexagonal boom profile

The hexagonal profile used on Hiab booms is a ground-breaking design introduced by Hiab many years ago. It is now standard throughout the market of loader cranes. Even the smallest of Hiab cranes benefit from this design.

Optional side supports

For cranes equipped with hose and pipe kit, side supports are fitted on each boom extension. These supports stabilize the boom laterally and minimize the play.

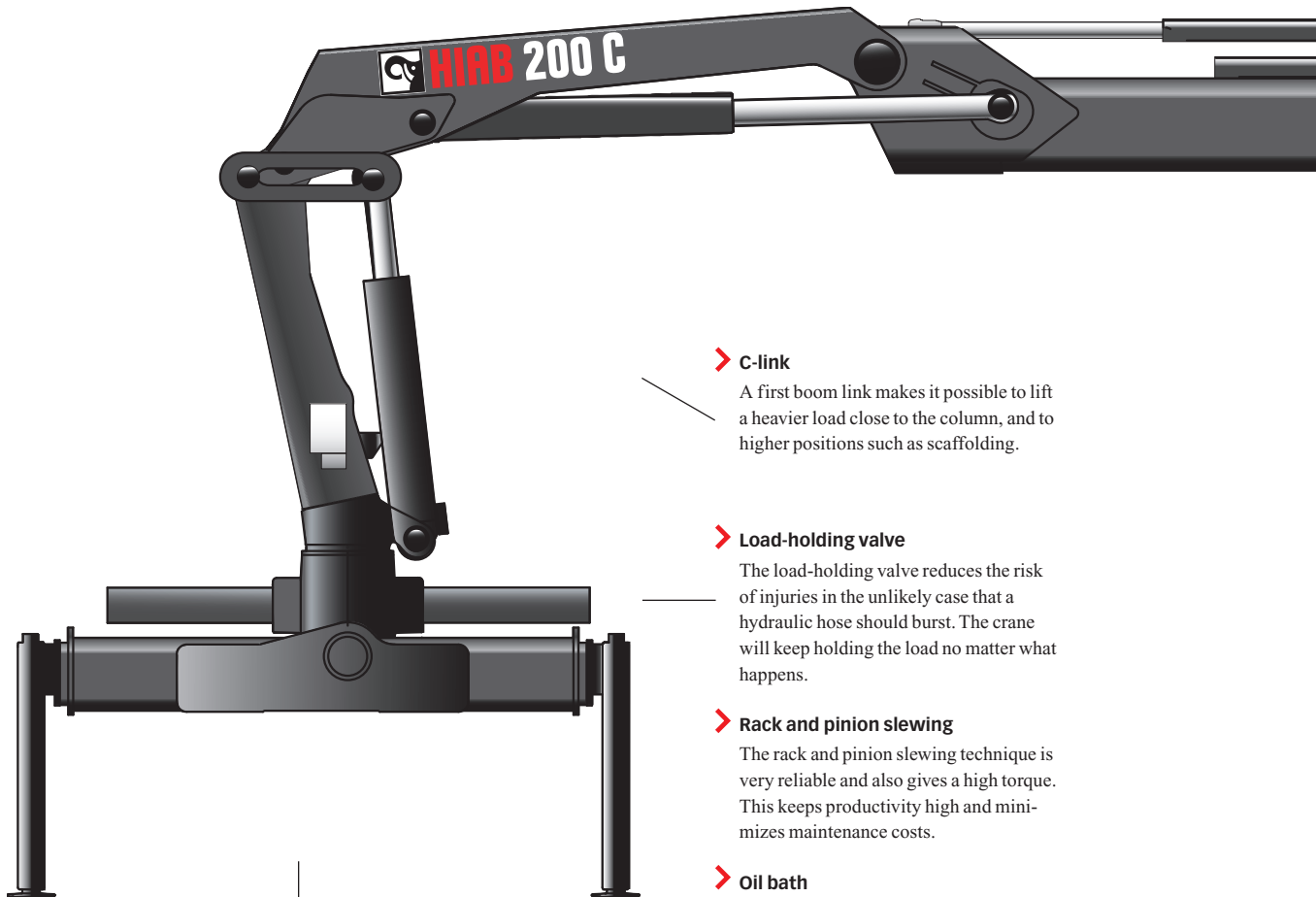

> C-link
A first boom link makes it possible to lift a heavier load close to the column, and to higher positions such as scaffolding.

> Load-holding valve
The load-holding valve reduces the risk of injuries in the unlikely case that a hydraulic hose should burst. The crane will keep holding the load no matter what happens.

> Rack and pinion slewing
The rack and pinion slewing technique is very reliable and also gives a high torque. This keeps productivity high and minimizes maintenance costs.

> Oil bath
On most Hiab cranes over six tonne metres the slewing mechanism is kept in an oil bath. This keeps the slewing mechanism in great condition throughout the years making sure the crane can be confidently used for extremely demanding applications.

> Hoses internally
The hoses are run internally in the crane body and in the outrigger beam, where they are out of harm's way, thus reducing maintenance costs.

> **Hexagonal boom profile**

The hexagonal profile ensures the boom is always in perfect balance, due to its shape and big support surface. The profile also minimizes boom deflection. This reduces maintenance costs and increases efficiency.

> **Low headroom**

The cylinders on top of the extensions are mounted so that they take up less space the further out they are positioned. This provides easy access to confined spaces, thus improving efficiency.

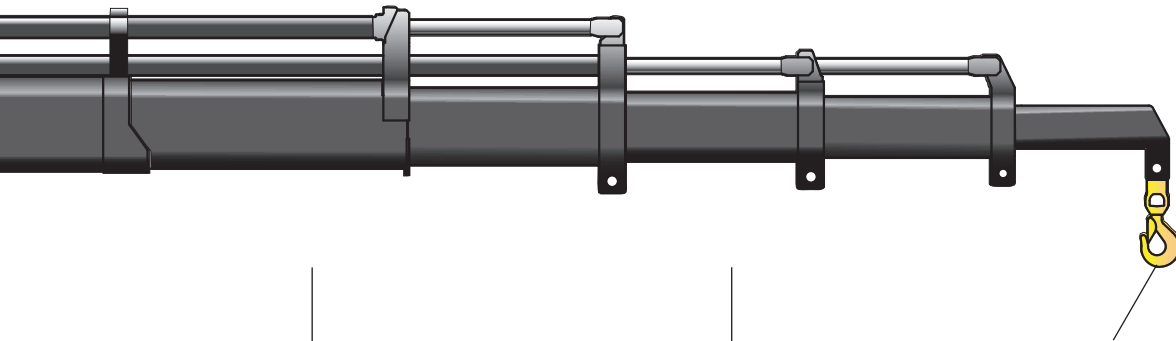

> **JIC couplings**

JIC couplings are standard on most Hiab cranes. They assure secure coupling easily, and are still very easy to disconnect for service.

> **Large slide pads**

The hexagonal profile enables the use of larger slide pads. This makes the extensions move smoother and reduces mechanical wear on the boom.

> **Attachable tools**

A wide range of attachable tools are available for your Hiab crane. These make sure you can carry out a lot of different tasks.

HIAB 200 C Capacity 20 tm

> Valve 91 (optional)

The HIAB Valve 91 represents the pinnacle of hydraulic valve technology. It is load-sensing and pressure compensated which improves both speed and precision. It features a long range of top class abilities, among one is that the same control lever movement always produces the same crane response, whether you are using one or more functions, with light or heavy load. This keeps the lifting and other crane functions running simultaneously at the same relative speed. The HIAB Valve 91 gives your crane the ability to be controlled with fingertip precision regardless of how far out the crane tip is, invaluable in confined spaces.

> Operating your crane by remote control

The benefit of Hiab's remote control units ensures that the crane operator can be positioned at the best possible location when operating the crane. This leads to more efficient, comfortable work and also increases safety. A further spin-off effect is that you can be your own loading assistant due to the fact that you can position your self next to the load, or wherever the loading assistant would be standing. Your tasks will be completed faster and at a lower cost.



> Remote control

A remote control enables you to stand at the best possible location for completing the task safely and efficiently.

> Valve 80

The HIAB Valve 80 is a top of the line open centre valve based on well proven technique which gives superb reliability. The valve handles large oil flows and provides great precision and ease of operation.

< C-link

The C-link system comprises of a first boom link which significantly increases the lifting capacity of the crane in high boom positions, especially when working close to the column. In practice, this could mean the difference between loading and not loading a heavy weight onto a truck.

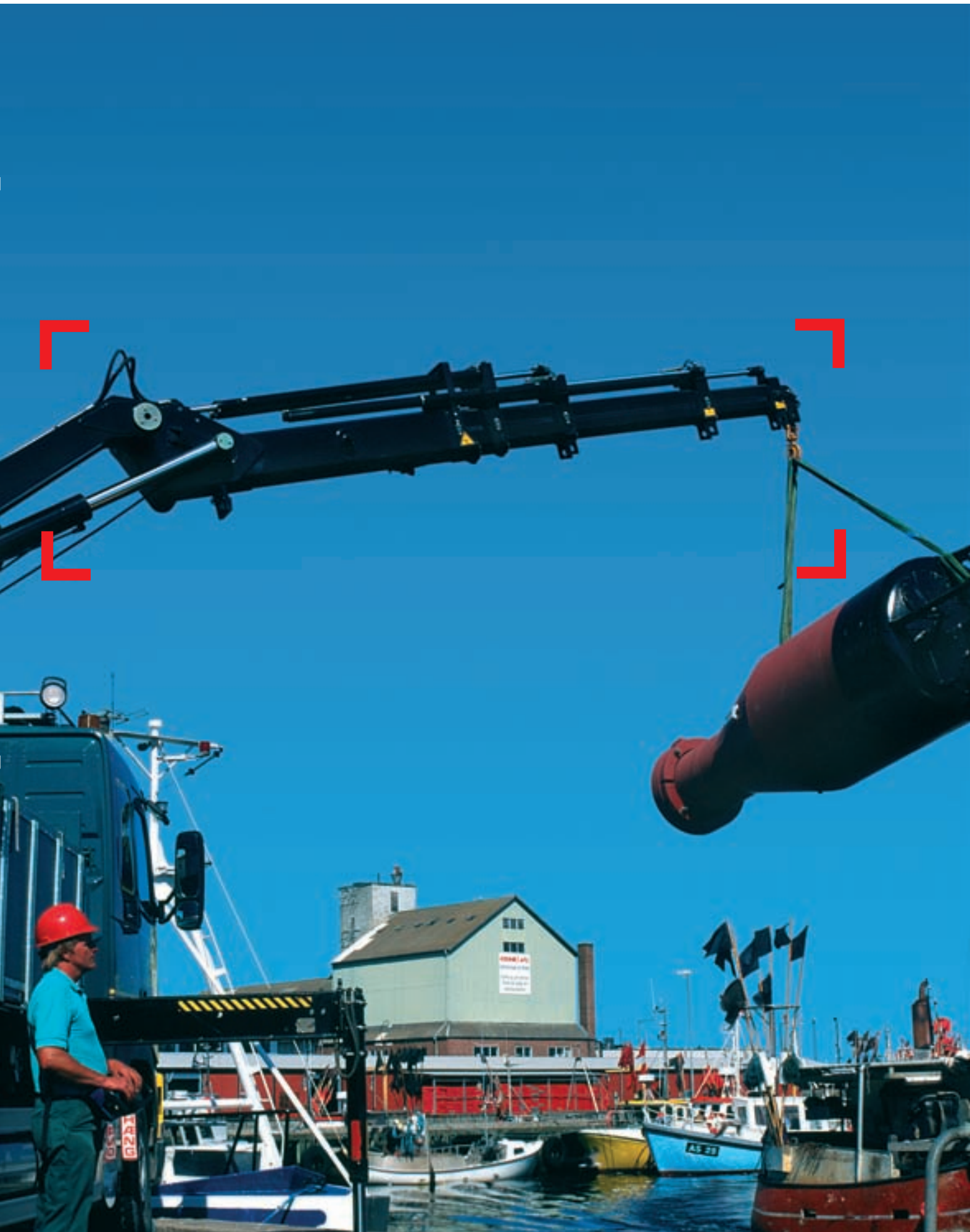



Hiab is part of Cargotec Corporation

